



Caring for
East Hampshire's
**CONSERVATION
AREAS AND
HISTORIC BUILDINGS**



EAST HAMPSHIRE



Partners

www.easthants.gov.uk

Introduction and Contents

This leaflet is one of a series of guidance notes published as part of the Conservation Directory for East Hampshire. It amplifies some of the policy guidance given in Planning Policy Guidance Note 15 (PPG15) and the East Hampshire District Local Plan

East Hampshire District Council places great importance on the protection and conservation of historic areas and the buildings within them. We provide here some brief practical advice to owners, their agents and builders about the ways to maintain, change or extend buildings which will help to preserve and enhance Conservation Areas and the historic buildings and spaces within them.

Contents

- 3 The Importance of Care.
- 3 Property Maintenance and Repair / Common Defects.
 - the roof, slates, tiles, roof timbers, thatch
 - chimneys
 - valley gutters
 - downpipes
 - walls
 - painting
 - damp
 - windows, doors and lintels
- 10 Alterations
 - roofs
 - windows and doors
 - colour of buildings
 - entrances and paths
 - walls, railings, fences and hedges
 - trees
- 18 Alterations to commercial buildings, offices, shops, public houses
- 21 Extensions to historic buildings
- 22 New development in Conservation Areas
 - some basic principles
 - key characteristics to consider
 - basic approaches to design
- 25 Enhancement of spaces in Conservation Areas
- 26 The role of statutory bodies and utilities
- 27 Further reading and information
- 27 Summary of points



Importance of Care

Conservation Areas have their own unique character which should be protected and conserved. One of the best ways of preserving historic buildings is to carry out regular maintenance and minor repairs. This also makes sound economic sense.

In addition sensitive design and changes to buildings and spaces will enable the intrinsic character of Conservation Areas to be maintained. This applies not only to householders and property owners but to providers of services too, such as utility companies, water, gas and other similar organisations.



Clear the building of damaging vegetation!

Maintenance and Repair

Regular inspections and "stitch in time" repairs are the best and most economical way in which to preserve and protect historic buildings; unattended defects can rapidly become more serious and costly to put right.

Try to establish the cause of the problem before starting any repair works. The help of a suitably qualified architect, surveyor or structural engineer may be needed.



The most common of all defects are described below and overleaf with basic advice on how to remedy them.

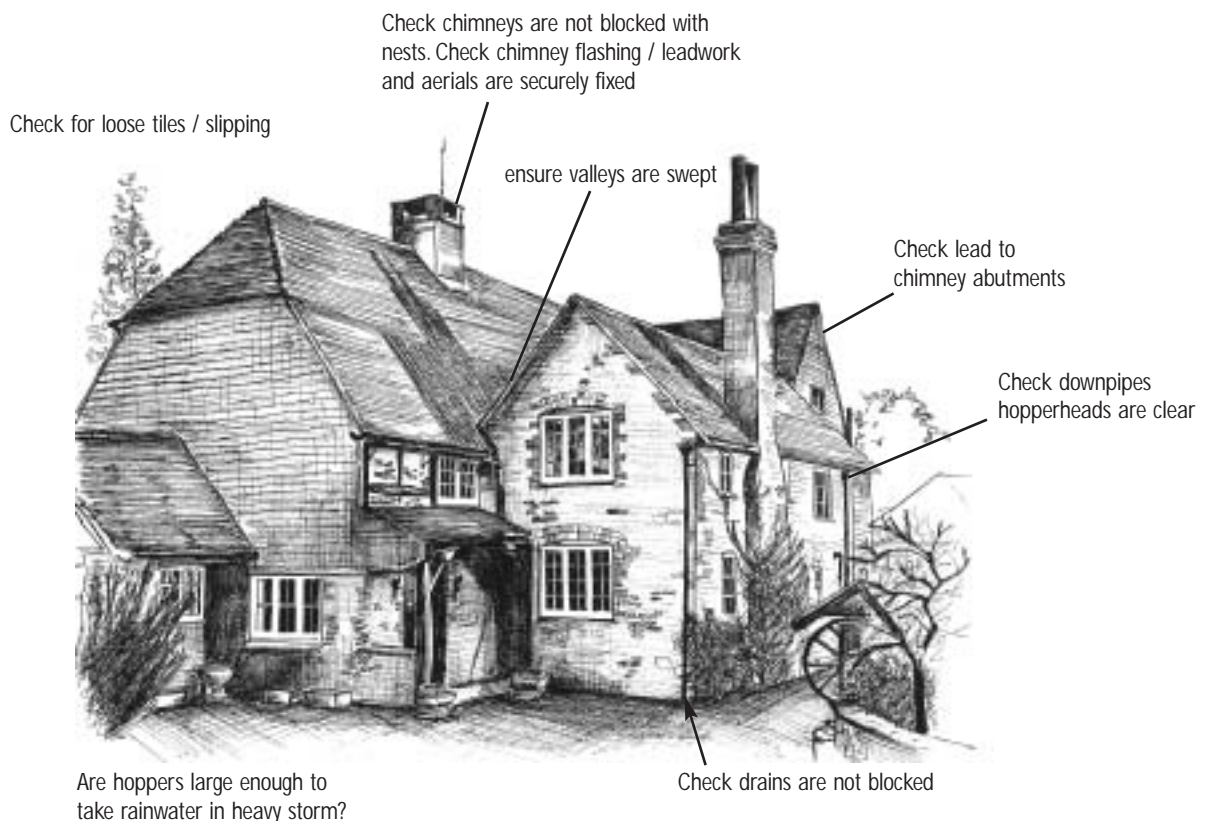

COMMON DEFECTS

The Roof - Slates, Tiles etc.

Roofs should be checked at least twice a year in early spring and mid to late autumn.

If a few slates or tiles have slipped or are broken it is possible to fix or replace them. Where the whole roof needs recovering, sound original materials should be salvaged with new or second hand making up the shortfall. Examine tiles carefully; most old clay peg tiles/nib tiles have a cross camber (a strong curve) or slope, which gives a texture to the roof as well as being practical by allowing water to run off properly and air to circulate underneath. Wooden (oak) pegs were originally used, thick galvanised or alloy pegs like a 'dumpy' nail with a wide flat head are now used.

The use of mortar, bitumen or fibrous paint repairs to hold together tiles, and glued wood blocks to repair slate are rarely effective. If temporary repairs to slates are needed it is best to use a lead tingle. Avoid using slates more than twice, unless they are very large slates.

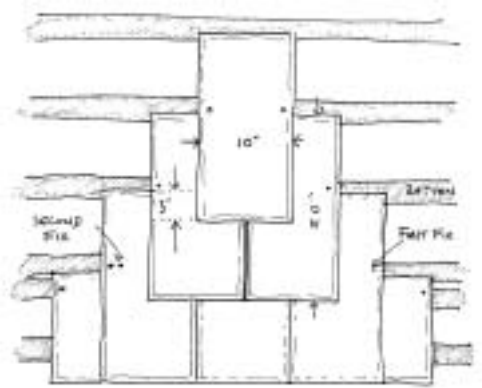
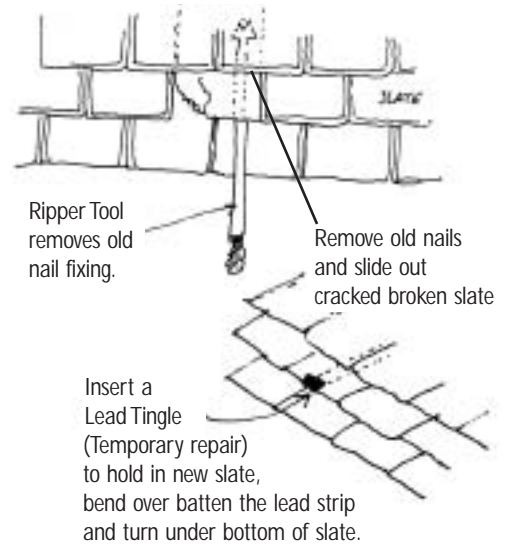
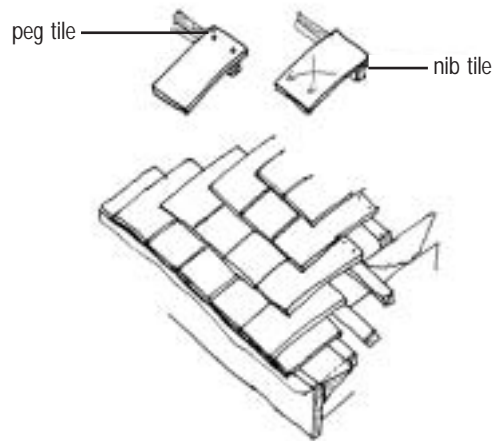

Fix slates for reuse once, avoid 3 fixings

Roof Timbers

These should be inspected at least every 5 years for signs of rot or beetle attack. Rot is quite common where the rafters rest directly on top of a wall or where there is a softwood timber wall plate on top of the wall.

Any sag or spread (where the eaves and wall tops may be pushed out) indicates a failure of the roof structure and professional advice should be sought.

If roofing felt is present then adequate ventilation should be provided between battens, tiles and felt.



rafter damage by deathwatch beetle and wet rots - a new oak section is best cut in to marry with old.

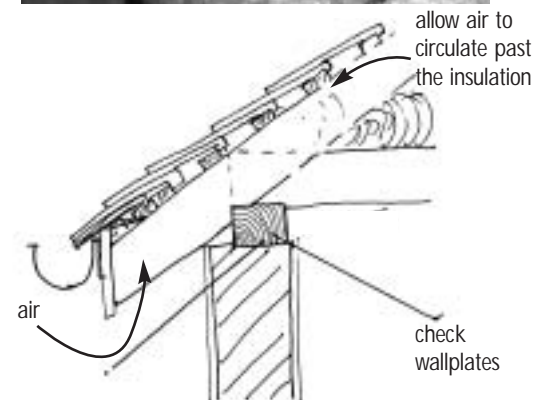

check rafter at plate, if broken or badly damaged, a new piece may need to be carefully cut in or a section of rafter placed alongside.

Thatch

The ridges and eaves of thatched roofs should also be inspected every 5 years. Check over the roof by looking to see if there are any narrow areas of worn thatch (slightly deeper furrows in the thatch) between the ridge and the eaves. A copper strip placed just below the ridge can assist the prevention of moss growth. Professional advice can be obtained from a thatcher who is a member of the Master Thatchers Association. (address at the end of this leaflet).

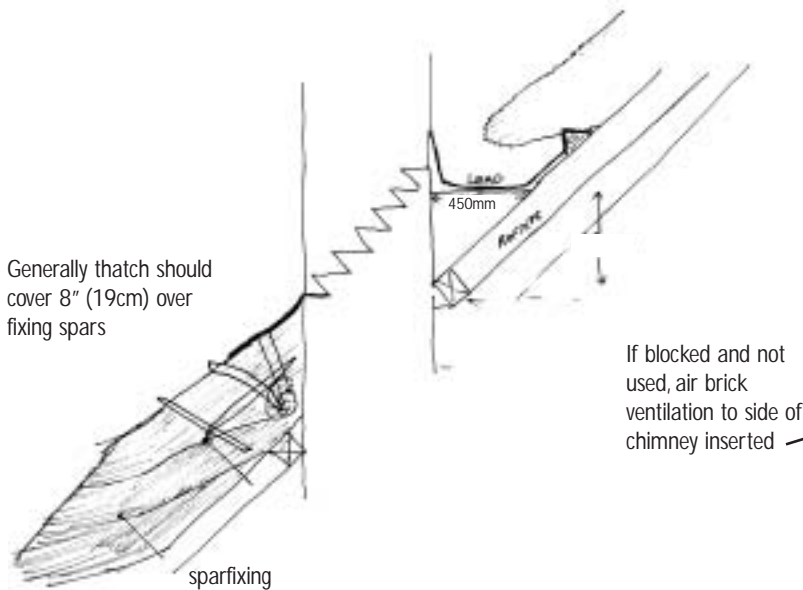

Tudor / Elizabethan fire place / chimney in timber frame

Chimneys

Check for leaning or bending of the stack and ensure the pointing of brick chimneys is sound (see also Walls). Significant leaning may require the rebuilding of a stack. The installation of a flue liner may prevent degrading of a stack in use.

The flashings between the roof edge and chimney should be renewed in lead if they are cracked or partly missing. Details are available from the Lead Sheet Association(address at the end of this leaflet).

Chimneys and their chimney pots which are not later 20th century changes should almost always be kept, even if no longer used. They form part of the character and visual balance of the building. Ventilation should be added to a blocked fireplace and a propriety clay capping or lead cover to the pot to help prevent condensation and damp.

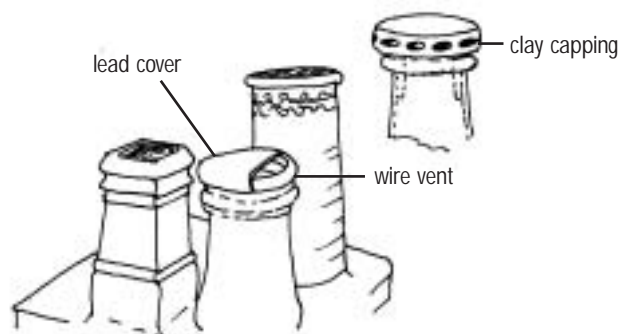
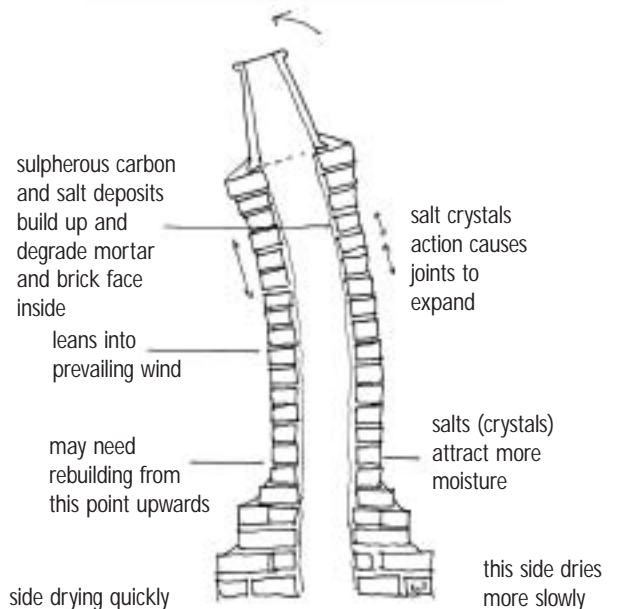
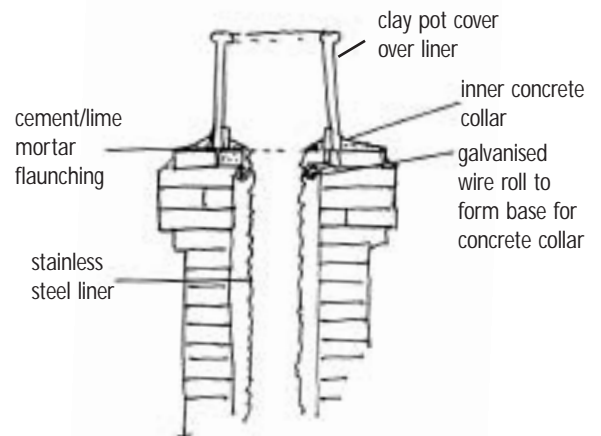

Valleys/ Gutters and Downpipes

Valley gutters and parapet gutters are wide lead lined areas between roofs or between the roof and a parapet wall. These should be regularly swept twice a year after autumn leaf fall and also in early spring. Check for cracks and wrinkles in the lead and worn areas usually where rain has dripped off a tile edge onto the lead, this occurs where the water mixed with air pollutants in rain creates acid which slowly dissolves the lead. This lead can become paper thin before eventually cracking. If you are able to fully repair the roof and are renewing the lead then make sure the weight and details are correct for the length and width of the valley (Lead Sheet Association) and consider placing a sacrificial lead strip at the tile eave, this will take the initial acid damage and the roof lead will last longer.

Only temporary repair measures can be undertaken by using proprietary peel off artificial lead over the worn area as this material has a short life. Check underneath the valley within the roof void to see if the valley boards are rotten. Clean out hoppers and if there are internal gutters, make sure the outlet is fitted with a stainless steel balloon in order to prevent clogging it.

Gutters and downpipes should be cleared at least once a year after autumn leaf fall. Inspect cast iron gutters and downpipes for cracks and rusting particularly at junction points and wall fixings. Plastic gutters are frequently inclined to loosen and fall at connections or bend and twist through the effects of heat and ultra violet light they also discolour and really should be regarded as temporary. In a public place the downpipes can unfortunately become the target of vandals; use cast iron wherever possible.

Cast iron, or wrought iron gutter brackets are often important features which may assist dating the building, they should always be kept where possible. Replicas or similar should be made if originals are beyond repair.

Downpipes also need inspection at the point they connect with the gutter and drains. Once cleaned out (to prevent corrosion) paint inside the cast iron gutter with a bitumen paint every 5 years. In order to ensure consistent movement and flexing of materials under a variety of weather conditions replacement gutters should be the same material and design as the original, cast iron or a timber and lead lined gutters should be retained.

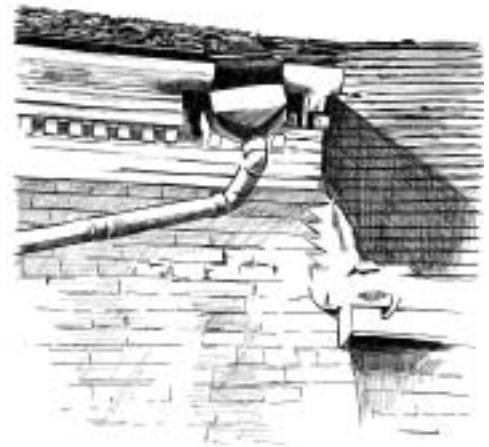

replacement gutters and downpipes like this rarely work particularly where there is a cornice use a large cast iron hopper head and a straight downpipe.

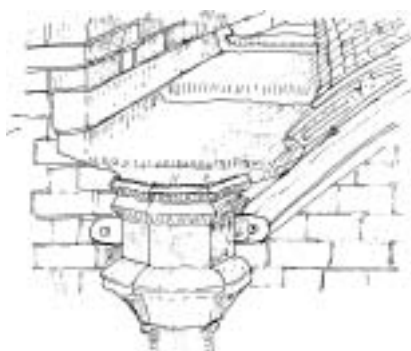
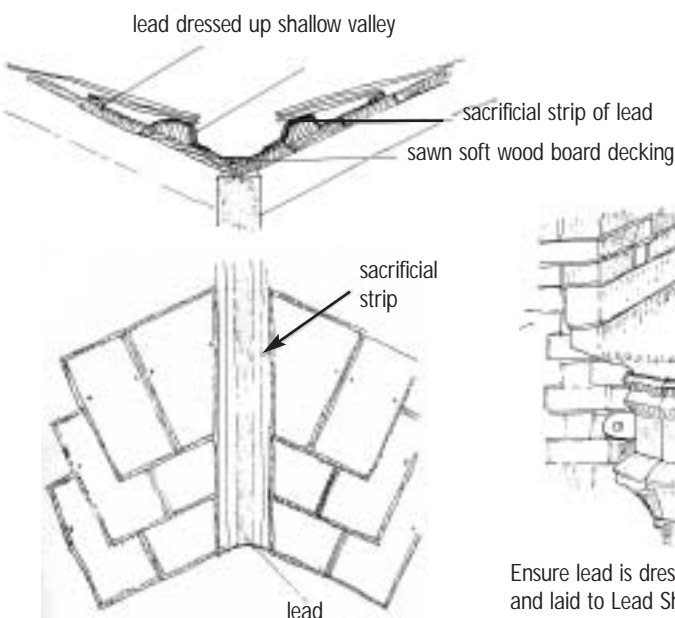
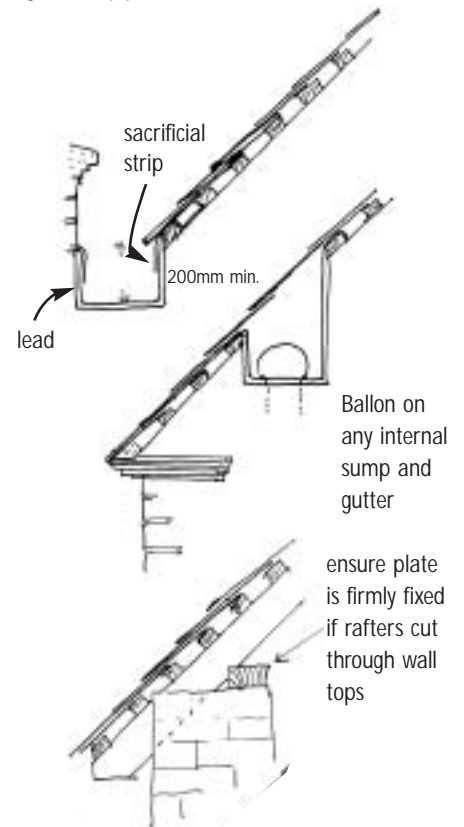

Ensure lead is dressed neatly into the hopper and laid to Lead Sheet Association Standards.



use ballons on vent pipes to prevent rodent / bird / leaves entry

Walls

If walls have continuous cracks and are leaning outward or are bulging then expert advice is best sought from a structural engineer, preferably one specialising in the repair of historic buildings.

Where re-pointing is needed only re-point those areas which are necessary and always use a lime rich mix. Old nail holes can be plugged with a mix of lime putty/silver sand/sand mix using a gun manufactured for the purpose. Eroded bricks or stone should only be replaced where this is structurally necessary. Replacement stone should match in colour, type and texture; the initial fresh colouring of the stone will soon mellow. Always ensure that the stone is correctly bedded. This work should be carried out by a qualified stonemason.

Where walls are timber framed check that the wall panels are held firmly in position if they are brick or rendered. Do not replace wattle and daub infill with another material, seek advice if they are loose or appear to be moving outwards. Also do not use any proprietary preservative on the oak frame as this prevents natural breathing of the oak .

Further advice on pointing is given in the leaflet - "Historic Building Repairs Advice - Mortars and Pointing". See back of this booklet.



Overhard cement based repointing will damage the stone as this prevents moisture evaporating through it.



The pointing on this building is soft and just back off the arris (edge) of the brick - it does not need repointing just because the mortar joint is soft and can be raked out by hand. The joint is doing its job allowing moisture to evaporate from the masonry.

Painting

Linseed oil based paints with lime were traditionally used for painting of timber and joinery in older buildings; sometimes together with a lime wash, which was also used for the walls. These have the advantages of allowing those materials to breathe. Most modern oil based and acrylic paints may cause problems to materials such as stone or brick. Further information on painting is available from, the Conservation Officers at East Hampshire District Council or from The Society for the Protection of Ancient Buildings.

Damp

Regular and appropriate maintenance should avoid damp problems which may be due to leaking gutters and downpipes, (check the gulley into the drain for blockage too) or a high ground level (above the floor level) or poor soil drainage surrounding the building.

Damp course injection into solid stone walls, particularly if it is the local more porous malmstone and if the walls are of some thickness, is likely to fail. The material is too porous or the walls are so thick that the injection is so arbitrary as to be ineffective. This will prove to be a waste of time and money.

In these circumstances invariably the best solution will be to increase the rapid drying out and ventilation of the building by removing water from the bottom of the wall. Constructing a pea gravel filled trench perhaps a French drain which assists drying out in the surface area surrounding and abutting the wall and can also divert water away from the wall is likely to be one good solution. Other wall vent methods may assist. Independent professional advice should be sought particularly on clay soils.



Vegetation can be a source of damp penetration at the bottom of solid masonry walls - remove a strip of about 2ft (750mm) around the building to allow moisture to evaporate and create air circulation to the base of the wall.

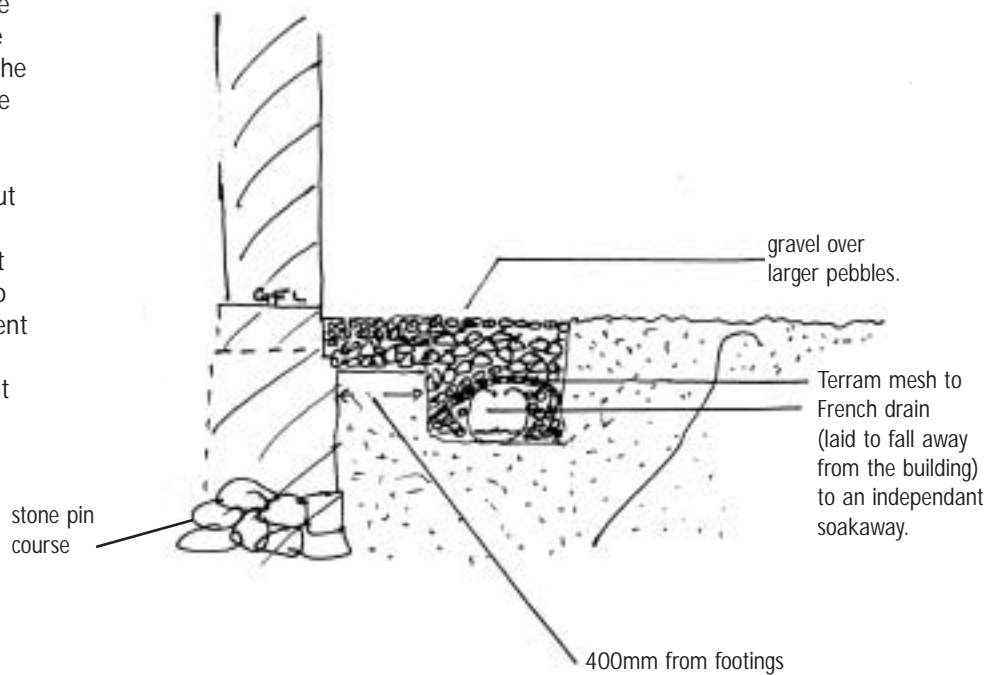

Cracked Lintels

Cracks in the render, stone or brick over a window is invariably caused by the failure of the timber or stone lintel. These can be repaired if they are of timber or re-supported by concealed steel plates. The advice of a professional surveyor or structural engineer who specialises in the repair of historic buildings should be taken.



Cracked lintel

Windows and Doors

These should be inspected every year for rot. Examine the sills and bottom of door frames. Windows which have been well painted from the outset will only need repainting every five to six years. New pieces, particularly for casement and sash windows or sills, can normally be fitted or cut (scarfed in) without needing to renew the whole window.

Original windows should always be kept wherever possible. If it is necessary to replace them, then the materials and pattern should be a replica of the original. Most older windows were painted, not stained in the modern 20th century fashion. Try to retain as much of the original timber as possible as this has an inherent strength and resistance to decay, modern softwoods are felled younger and preservative treated, this treatment can leach out over time allowing the timber to be more vulnerable to the elements.



Horizontal sliding sashes can be found too.

meeting rails



Vertical sliding sash with elegant narrow glazing bars

17th Century Mullion and Transom, iron casements and lead lights.

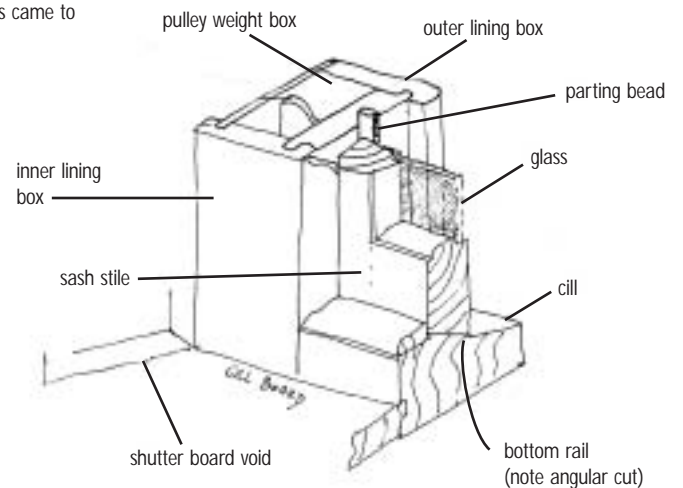
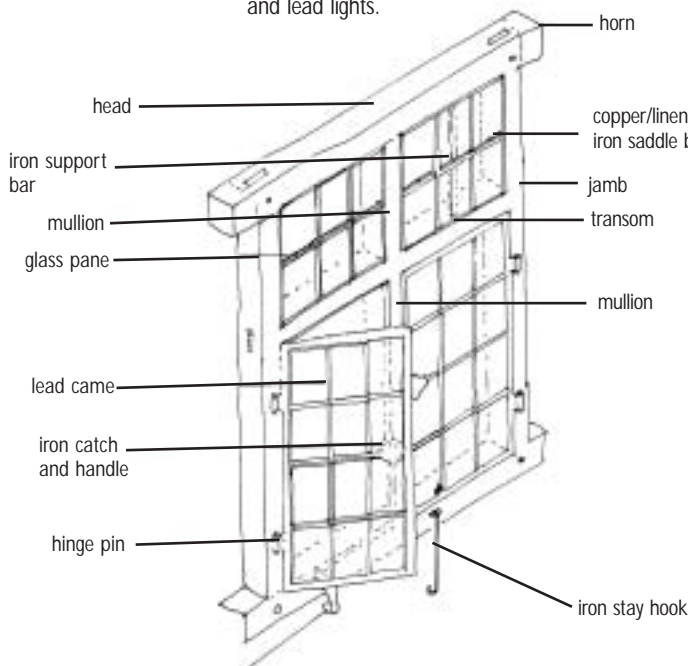

Alterations

The use of local materials and skills once dictated the height and span of buildings and the width of lintels over windows; all of these materials provided the constraints to determine the overall form of the building. The use of the building also helped determine its layout, together with the land form and local climate. The outcome of this was a local style or "vernacular". Changes have occurred over the years to this vernacular through technology but it is only in the last forty years or so that technological advances have meant virtually anything in building can be achieved, this can have advantages but it also needs control and guidance.

Alterations need to be carefully considered to avoid spoiling both the buildings character and that of the surrounding area.

A period property will be more likely to maintain and improve its value if this has been well looked after and retains much of its original features rather than one which has been poorly modernised. This is particularly important if the building forms part of the overall character and intrinsic value of the area.

The gradual removal of original features such as doors, including internal ones, windows, chimney stacks and roof details on a piecemeal basis will not only decrease value in a property but will ultimately destroy the integrity and character of both the building and the Conservation Area. It is advisable to keep alterations to a minimum and repair rather than replace original features. Listed buildings can be regarded in the same way as Antiques, modern repairs or alterations can devalue them.



Simple handrails do visually better than modern over-decorative replicas of late Victorian castings.



The elevation of this building is still well balanced despite the inclusion of the bay window alterations.



Always repair original details like these windows.

Changes to Roofs

The roofline is a dominant feature of most buildings. The retention of the original shape of the roof pitch and use of original roof material is important. Generally most roofs in East Hampshire are pitched and of various styles depending on their roof covering.

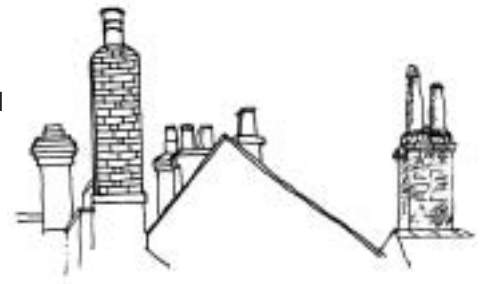

- Roofs are either plain gables, hipped or half hipped.
- The width of the domestic building is determined by the materials available and timber trusses had narrow spans.
- Materials used depend on the pitch of the roof, they include plain clay tiles and later Welsh or Devon slate.
- Thatch is usually Long Straw although Combed Wheat Reed is also used in East Hampshire. Reed is most rare and except near rivers unlikely to be local.
- Modern materials such as concrete plain tiles and asbestos slates are poor substitutes and are best avoided on old buildings.

Chimneys are a key feature of the skyline in many Conservation Areas. Most chimney stacks are located astride or close to the ridge and /or on gable ends. They are very "solid" in appearance due to the need to serve several ground and first floor flues; they should always be retained and if unused vented in the stack internally.



Roofsapes are a key character of towns and villages



Retain original roof materials and windows - modern ones look out of place.

Changes to Windows

The design of windows is of key importance. Careful consideration should be given to the following:

- The size and position of windows
- The relationship of windows to walls. Traditionally the walls dominate over the window. Where wider openings occur in later buildings these were subdivided by vertical post supports (called mullions).
- Modern windows should echo the vernacular details used on the buildings in the area. Most traditional windows are made of timber and are one of four types:
 - Fixed non-opening
 - Casements side hung
 - Vertically sliding sashes (and occasionally horizontal sliding)
 - Mullioned or transomed
- Windows should be proportioned so that elevations "balance" i.e.. they are in scale with the building itself.
- New windows should relate to other windows in the building, for example, these may be either strongly vertical or horizontal in emphasis.
- Avoid top hung opening lights (fan or corner lights) with plain casements: these create imbalance to the elevations.
- Avoid off the peg " Neo-Georgiana or Victoriana" style windows. The proportion of these windows are much larger than their earlier counterparts and they have poorly detailed and crude joinery, they debase authentic details.
- Avoid UPVC substitutes for joinery: these also have crude and flat details and are obviously fakes, they are also not maintenance free as many of the companies who promote them suggest. The surface can degrade in sunlight and rubber/synthetic gaskets can fail through heat and sunlight too.



A mullion / transomed stone window with iron frames and lead lights.

A simple mullioned casement - lead light and iron window with a cambered head, early 19th Century.



opening light



A late Victorian sliding sash part of a bay window. Note decorative horns, locally these are post 1870.

Changes to Doors

Entrance doors are traditionally located on the main elevation and are usually of a simple design. Original details should be retained wherever possible.

Careful consideration should be given to the following:-

- Seek to retain original features. Unless they are late Victorian, most doors were either panelled or vertically boarded (wide boards) without glazing.
- Glazed fan lights over doors are used to provide natural lighting for the hall.
- Replacement doors for older buildings and extensions should follow the traditional form. Door details, foot scrapers and ironmongery should always be retained. Try to match the originals.
- Many secondary doors were of a plain ledged and braced type with wide 6-8" (150 mm - 200 mm approx) vertical boards and should be kept.



A well proportioned Victorian door with fanlight and glazed upper panels.

This late 17th century door of two fielded panels used 'H' / 'L' hinges pinned with dog nails not screws.

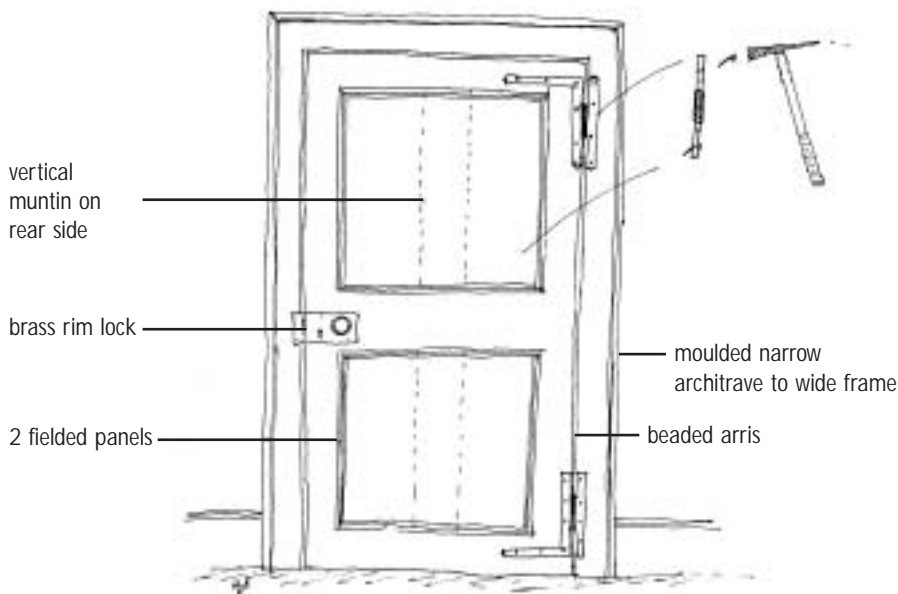

Original doors have been lost and modern psuedo Georgian (American Kentucky) have unfortunately been inserted.

A pair of Victorian houses in a terrace with their original windows and doors (5 panels) and ironmongery unaltered. The walls would have had cast iron railings on them with a similar cast iron gate to match.



Garage Doors

Low, wide openings such as double width garage doors are rarely found in old buildings and should be avoided.

- Garages are best detached from or subservient to the main house in a low building or coachhouse style.
- A pair of wooden doors give a better appearance, these should be vertically boarded.
- Modern metal "Georgian" style panelled garage doors have no historic precedent and should be avoided.

Colour of Buildings

The use of paint and colour in old buildings in Conservation Areas can make a major contribution to their overall character. Terraces of cottages or houses retain their architectural integrity where colours and windows and doors are uniform.

Village houses retain their overall character best where the range of colours used on windows, doors, gutters and downpipes is kept to a minimum. Gutters and downpipes are best painted in unobtrusive colours such as black, dark brown or dark green. Lead rainwater goods should normally be left unpainted as painting may damage the material.

Traditional casements or sash windows on domestic historic buildings should be painted in one colour; this colour would normally have been white or cream. Farm buildings may have had darker colours e.g. claret red or bottle green.

The stripping and subsequent staining of originally painted windows should be avoided particularly on residential buildings. This is a modern practice which alters the original style and character of the building, adversely affecting its overall impression of balance and proportion.

If the building is a barn conversion and the walls are constructed of brick or stone, then painted windows are more appropriate. If however the barn has dark weatherboard on its elevations then dark stained windows should match exactly the colour of the boarding as appropriate. Weatherboarding was normally tar pitched black and similar materials are still available. Some barns were also limewashed and this is a cheap and easily useable material still available.



Mill and granary conversions - painted windows suit masonry



ENTRANCES, LOCAL PATHS AND YARDS

Paths leading to buildings, footways and farmyards are important in contribution to the character of a Conservation Area.

Traditional paving surface materials used in the District included:

- York stone and limestone flags and setts (Selbourne and Alton)
- Red/Blue brick (Alton (post 1867) and some entrance paths in Froxfield)
- Stable yard brick setts (Liss and Holybourne)
- Blue ragstone and flint cobbles (Selborne, Alton)
- Ironstone cobbles and wedges (Blackmoor, Greatham, Liss, Headley, East Tisted, Binsted and Liphook).
- Gravel which is used as an informal surface for exteriors to buildings, paths and yards throughout East Hampshire.



Cobbles and wedges, Blackmoor



Herringbone brick, Alton

WALLS, RAILINGS, FENCES AND HEDGES

Walls, railings and fences can make a significant contribution to the character of particular Conservation Areas. Many walls are listed in their own right and have special protection.

a) Walls

Walls define public and private space and new walls should do the same. Low walls, i.e.. below 3 feet or 1 metre are generally inappropriate.

Most stone walls in East Hampshire villages are constructed of coursed rubble malmstone or ironstone and sometimes flint. These walls are often galletted (small stone chips in the pointing).

Old walls should be retained wherever possible. If they must be demolished then they should be rebuilt using the same materials to the same height and size.

Repairs and alterations to existing walls should always be in the same material and bond. In particular the original coping should be retained. Brick walls of Edwardian, Victorian or earlier date are normally red/orange in colour and a smooth locally fired brick, sometimes burnt blue is featured or as blue headers - a blue vitrified (shiny surfaced brick was also used for pattern work. Bricks on edge were also used.



A well laid local malmstone wall with banded coursing using large bonding stones after 6 or 5 narrower courses.



An ironstone wall with sandstone (churt) quoins and galletting (stone chips) in the mortar joints.



Attractive walls contain the building and contribute to the street scene.

b) Railings

Railings are an important feature of many buildings within a town or Village Conservation Area and should always be retained and repaired.

The practice of painting gold tops to railings is essentially a city based one and should be avoided in villages and country towns where they were almost always painted black, dark blue, or in some instances surrounding gardens or parks, in dark green.

There are generally two types of railing-

- vertically divided with narrow openings which are applicable to town and village houses, normally set close to the road
- park railings- which were used principally to retain livestock and provide a boundary for hedges to more substantial houses and manorial estates. This detail is often found surrounding the parkland of a manor house or estate cottages.



Town railings



Rural 'park' railing

c) Fences

There are many types of fences which are used to serve different purposes.

Timber palisade fences will normally only provide protection to a hedge and define a property boundary. They will allow some light through and allow vegetation to grow between and be seen through them. On the other hand close boarded fences shut out the view and light completely and provide a stark and ugly edge to the road. These should be avoided.

Picket fences, if painted white, provide an interesting feature and setting for small country cottage gardens particularly for terraced Victorian housing.

d) Hedges

Hedges often have a softening effect. They too serve a more specific purpose, giving privacy and screening. Hedges can also provide enclosure to views and visual links between buildings and their setting. Together with trees they form an important part of the character of many conservation Areas and should almost always be retained and their planting reinforced. There are various traditional styles of old and 'ancient' hedges throughout the district including layering and coppice. These should be kept.

e) Trees

The care of trees is vital to the character of Conservation Areas- the detailed advice is available in the Conservation Area leaflet for the area and in the following leaflet: "Trees and the Law" and "Tree Planting - A Guide" available from East Hampshire District Council, Planning and Development Services, details at end of this leaflet.



picket fencing



Walls and Trees are an important setting for buildings

Alterations to Commercial Buildings, Offices, Shops, Public Houses

Alterations to these buildings normally occurs where there are new owners or new uses. PPG15 expects listed buildings to be preserved, except when a convincing case can be made for their alteration or extension. Applicants will need to justify why works which affect the character of a listed building are necessary. It is important to consider the long term effects which the alteration will have on the building and its surroundings, and also its long term vitality and not just the short term commercial gain.

Applications for change of use for historic buildings, particularly those that are Listed as Buildings of Special Architectural or Historic Interest, are considered most carefully by the District Council. Approval for the conversion is unlikely to be allowed if the works involved will result in the loss of the buildings character. Most changes of use will involve alterations which should be carried out with skill and sensitivity.

The Council will normally resist proposals for changes of use which would result in the deterioration in the maintenance of historic buildings, for example, if upper floors space are likely to remain unused.

Specific internal changes which can be particularly damaging to both the maintenance of the historic building and its historic interest include:-

- The blocking up or removal of a staircases leading either to the upper floor or to cellars. This can lead to the under-use of these parts of the building and allow decay to proceed undetected.
- The removal of internal walls to provide larger rooms or in order to create a large area of "standardised" retail floor space. This removes much of the interest from the building and can mean reduced maintenance of the fabric of the building's upper floors. The wide span steel frame required to support the floor often necessitates further structural alterations which will detract from the buildings character and ultimately leads to a complete loss of the buildings historic interest.
- Raising, lowering or removal of existing floors to provide room heights of the standard commercial requirements currently in vogue. This can lead to unusable or inaccessible voids between floors and an unworkable and visually poor relationship of the floor to existing windows when viewed from the exterior. This may also lead to further structural problems and later alterations. Internally this also removes the important intrinsic historical and archaeological evidence from a Listed Building.

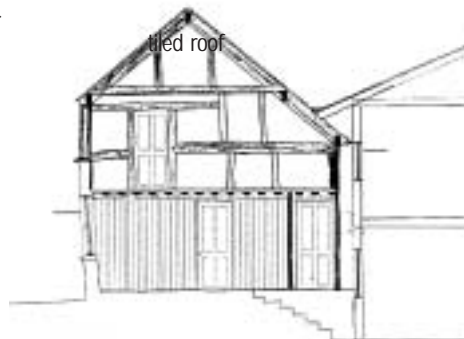

new and old may need to be accessed by a separate staircase

slate roof

lead valley gutter



Floors in historic buildings may not be at uniform levels throughout. New build will need to consider this.



Signs can contribute to the street scene itself - helping to create an 'atmosphere'

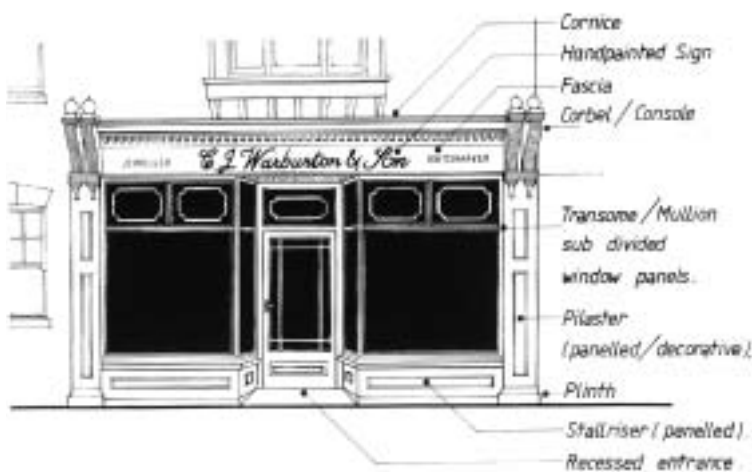

A traditional shopfront and its surround



Traditional new shopfronts fit into the street scene - Normandy Street, Alton

Shops and Shopfronts

A shopfront can also mean the facades of banks, building societies, estate agents, offices, public houses and hotels. Their design can have a considerable impact on the appearance of the Conservation Area as do the advertisements which are displayed upon them.

The introduction of a new frontage, which does not respect the material and design of the building itself and its surroundings, can incrementally severely damage the whole appearance of the Conservation Area and its future economic health.

New frontage designs should:-

- Reflect the individual character of the building.
- Reflect the window patterns above.
- Avoid wide and deep fascias.
- Avoid large areas of plate glass.
- Avoid plastic details.
- Provide interest and variety in design, echoing the building frontages around them.
- Avoid inappropriate lighting.

Adverts and signs are an integral part of the commercial frontage and should reflect the design of the building, they can also contribute to the atmosphere and street interest of a place in their own right. Traditional signs should be hand painted. Pull out blinds are more suitable to the character of Conservation Areas and shiny wet look curved type awnings should be avoided as these will degrade rapidly in sunlight and soon appear 'un-kept'. Further detailed guidance is set out in the leaflet- "Shop fronts: A Design Guide for East Hampshire" and also the Advertisement guidelines.

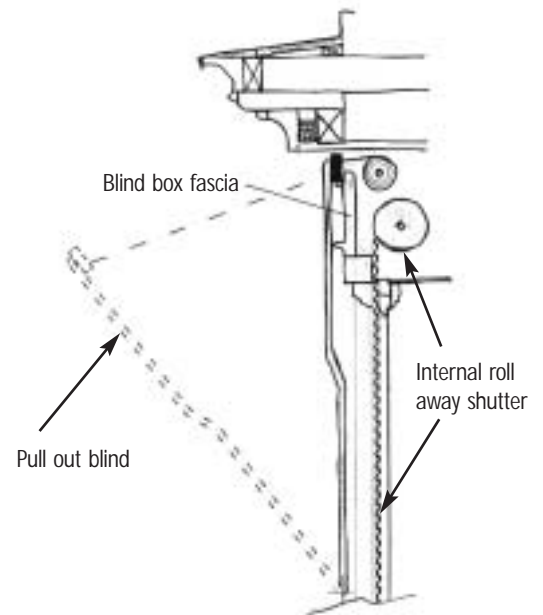

The Harrow, Steep. One of the most original in Hampshire with its divided bars intact.



The White Horse in Alton retains most of its original medieval timber frame inside.

Shops: Security Measures

Due to the problems of shop security there is a possibility that measures will be needed to deter the breaking of shop windows. Windows can normally be fitted with reinforced glass, alarm strips and internal grilles. Most plain glazed shop fronts can be redesigned to incorporate glazing bars.

If external security fittings are to be installed they should be:-

- Designed to be an integral part of the shop front and not detract from any architectural feature. To retain interest in the street at night, the shop interior and overall area should be visible when it is closed. Totally obscure shutters provide no interest and this in turn only serves to discourage use of the town at night by inhabitants and visitors.
- Painted and finished to blend in with the shop front.

The security industry is looking at methods of providing more visually sensitive methods of shop protection and these should be explored by owners and occupiers of shops within Conservation Areas.

Applications for new shops or commercial frontages within Conservation Areas should include the details of the shop frontage at the time the application for the building is submitted.

Before discussing proposals with the District Council and making a formal application, owners and occupiers are advised to read the guidance note - "Shop front - Design Guide for East Hampshire and the Conservation Area Guidance Note leaflet for the Conservation Area in which their property is located.

Public Houses

Traditional public houses and inns originally had a characteristic of their own. Victorian pubs in particular have their own style of frontage, particularly below the first floor.

Original features should always be retained. Public houses should not seek to mimic earlier buildings by inserting fake beams. It should be possible to provide attractive decor in the interior of the pub to suit its age of construction or to update in a contemporary but attractive way.

There are several guides published on good practice and these are set out at the end of this leaflet.

The internal arrangement of public houses is often of historic interest and proposals which remove sub-dividing walls within public houses will normally be



Extensions should generally be subservient to the original building



Occasionally the design can be repeated eg. in a terrace, this needs careful skillful detailing

resisted. Owners, occupiers and publicans are reminded that Listed Building Consent will be required for any changes to the exterior and interior which affect the character of Listed public houses.



Extensions to Historic Buildings

Extensions are one of the most frequent changes made to buildings in Conservation Areas. Too large or poorly designed extensions not suited to the original building can cause irreversible damage to the street scene. Well designed additions, however, can add to the richness and appearance of a building. The advice given in PPG15 will influence the Council's decision making on planning applications

A well designed extension depends on finding the correct balance which respects and harmonises the original design with that of the new building.

There are four key factors which most often determine a successful extension design.

- Extensions should always appear subservient (smaller in mass and scale) in design to the main building.
- The extension should look as though it could have been part of the original design although it should not necessarily replicate the original.
- Care should be taken to avoid upsetting the visual balance of the elevations. Many older buildings are asymmetrical and can stand change to their composition. However, extensions to more symmetrical buildings of the 18th and early 19th century need careful design which does not alter this symmetrical balance.
- A more modern approach needs to be carefully considered, be imaginative and complement the original building.

Before putting ideas on paper for an extension, study the existing building carefully to ensure that its best qualities remain when any changes are proposed.

Look at:

- the form of construction, particularly the roof pitch.
- the outline (profiles) of the building
- window style and pattern
- the position and detail of existing and new doors and entrances.
- how you intend to use the extension and where people will circulate in particular what are the entrance and exit points from the original building.

For residential buildings more detailed information is set out in the guidance note "Extending Your Home" - Design Guide for Residential Extensions.



modern interpretations of a traditional form



gable forms in a modern way



modern classical design



New Development in Conservation Areas - Some Basic Principles

Conservation Areas can be easily damaged by change which is insensitive to its surrounds through inappropriate size, scale, details or special treatment. New buildings must acknowledge the characteristics of the local traditional building form in the existing development, the use of local materials should also be respected.

New buildings can be imaginative yet they should also seek to blend into the landscape and/or townscape which surrounds them rather than impose themselves upon it, if they do this will need to be a development of such quality as to provide both a significant and positive landmark contribution.

Key characteristics to consider when proposing new development

- Height of surroundings buildings should harmonise with the new buildings.
- The roof, its form and skylines e.g. pitch, gable, eaves, hipped roofs, flat roofs, parapets.

The overall form of development -

- the pattern of building surrounding the new building.
- the size and mass of nearby buildings.
- type; terraces, semi-detached, informal groups.
- the position in the street, narrow lanes, footpaths etc.
- the size of spaces/gardens between buildings.
- proportion/ratio of windows to walls; traditionally the wall dominates over the window.

- Materials; local use of stone (ironstone, chalk, malmstone) painted plaster or stucco, red/orange/blue brick tile hanging, slate or plain clay tile roofs or tile hanging

- Landscape setting; buildings are often "framed" by trees or have a background of trees and hedges creating a sense of enclosed space.

New building should always be 'in context' with their surrounding buildings. This does not mean that new buildings should necessarily replicate the original but they should take account of the following:-

- the site and its proximity and relationship to existing buildings.
- the strength and pattern of the basic design of the existing.
- the overall individuality and sense of place that those existing spaces, materials, mass, form and modelling of buildings have created over time.



The use of local stone as a cue for the setting of a modern design.

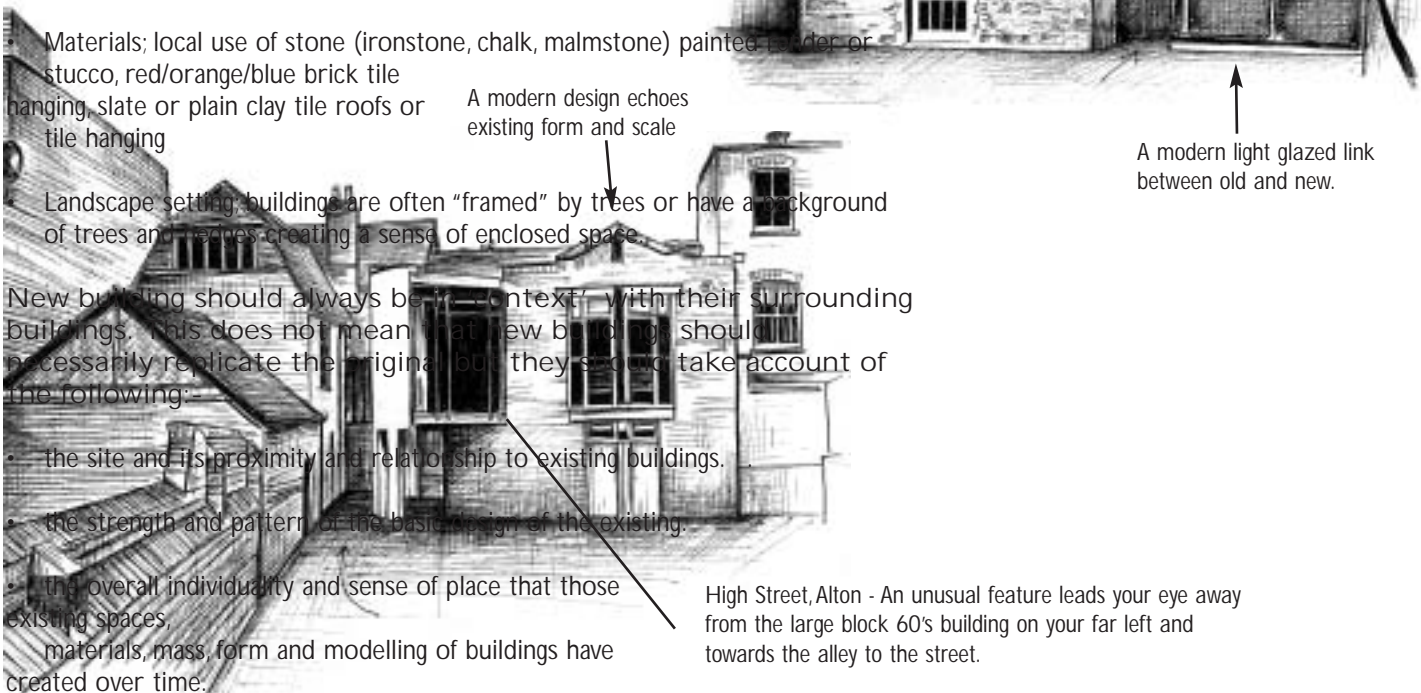

A modern design echoes existing form and scale

A modern light glazed link between old and new.

High Street, Alton - An unusual feature leads your eye away from the large block 60's building on your far left and towards the alley to the street.



Trimmers Walk, Alton



The Plestor, Selborne



Dragon Street, Petersfield

THREE BASIC CONTEXTUAL APPROACHES CAN BE ADOPTED TO DESIGN.

These can be described as:

- Interpreting the form of the existing buildings in a modern way.
- Imitating or repeating existing designs.
- Modern - contemporary design.

Interpreting - using the existing building form in a modern way



This terrace of unaltered Victorian housing would benefit from the lamppost being in a more sensitive position or relocated to the large open pavement area on the opposite side of the street.

This entails the use of existing form, materials, fenestration (the relationship of windows to walls) and pattern and a good understanding of the nature of local materials, details and construction history such that a building is designed which both closely echoes the existing buildings yet its appearance clearly uses construction in details which are of today.

Imitating - or repeating existing designs.

Such designs are most difficult to achieve given modern construction standards and building requirements but the key factors governing successful schemes are the following:

- adherence to the use of local materials
- repeating the spans, height and depth of original buildings particularly roof spans and pitch
- quality and attention to detailing and features such as windows, doors and eaves.

- getting the scale to match existing buildings.
- a simple design, well detailed.
- pattern and orientation needs to repeat the existing.

Too many new building designs which seek to imitate or pastiche the original designs perhaps ultimately fail because modern requirements of construction standards are incompatible with the size and scale of earlier buildings and careful skills are required to overcome this.

Modern - Contemporary Design

Such an approach uses new (modern) ideas, materials, details modern living style, form and fenestration.

In most instances such modern designs are generally best suited to spaces which are more isolated from the street scene and rather more detached from the original pattern of building although such sites present a challenge for modern imaginative design solutions.

Designers can either provide a contrast with the existing or complement it.

The more successful contemporary building designs are those which;

- respect their location and landscape/townscape surroundings.
- respect and are compatible with the overall form of the surroundings
both built and natural landscape.provides interest, imagination and public space.
- the detail of the building its surroundings approaches, entrances and exits are
of the highest quality.

As part of applications for Planning Permission new proposals will need to include a DESIGN STATEMENT which shows why and how the particular design chosen design has been arrived at and why other design ideas were rejected.